

SoftPLC Web Studio - HMI Models SSH-3CLT, -3CLP

FUNCTIONALITY		
Model	SSH-3CLT	SSH-3CLP
Tags / Drivers	150 / 1	300 / 1
Operating System	Windows CE	Windows CE
Storage	32MB Flash on board	32MB Flash on board

SPECIFICATIONS				
SYSTEM HARDWARE		LCD DISPLAY		
CPU	312MHz Intel XScale PXA270	Display Size / Type	3.5" QVGA TFT LCD	
Ports	LAN	(1) 10/100Base-T	Max Resolution	320 x 240
	Serial	(1) RS-232/485	Max Colors	64K
	USB	(1) USB 1.1 host	Luminance cd/m ²	200
	Other	n/a	Viewing Angle (H/V)	120/110
Expansion	(1) SD Card	Backlight Life	30,000 hours	
Memory	64MB SDRAM	Contrast Ratio	300:1	
Watchdog Timer	Programmable-250ms/500ms/1sec	ENVIRONMENT		
TOUCHSCREEN		Humidity	10 ~ 95% @ 40°C, non-condensing	
Lifespan (min)	1M activations	Ingress	Front Panel: NEMA4, IP65	
Light Transmission	Above 80%	Vibration	1 Grms (Operating, Random)	
Resolution / Type	Linearity / 4-wire, analog resistive	Temperature	Operating 0 ~ 50°C, 32 ~ 122°F	
		Storage	-20 ~ 60°C, -4 ~ 140°F	
		Certifications	BSMI, CCC, CE, FCC, UL	
MECHANICAL				
Enclosure	ABS	Power	Consumption	8W
Weight (Net)	0.25 kg, 0.55 lbs		Input	8 ~ 28VDC
Cooling System	Fanless Design	Recommended Power Supply		ICO-PS4024
Dimensions (WxHxD)	4.76 x 3.37 x 1.04 in	120.8 x 85.5 x 26.5 mm	Panel Cut-Out Dimensions	115 x 79.5 mm

Dimensions Units=mm

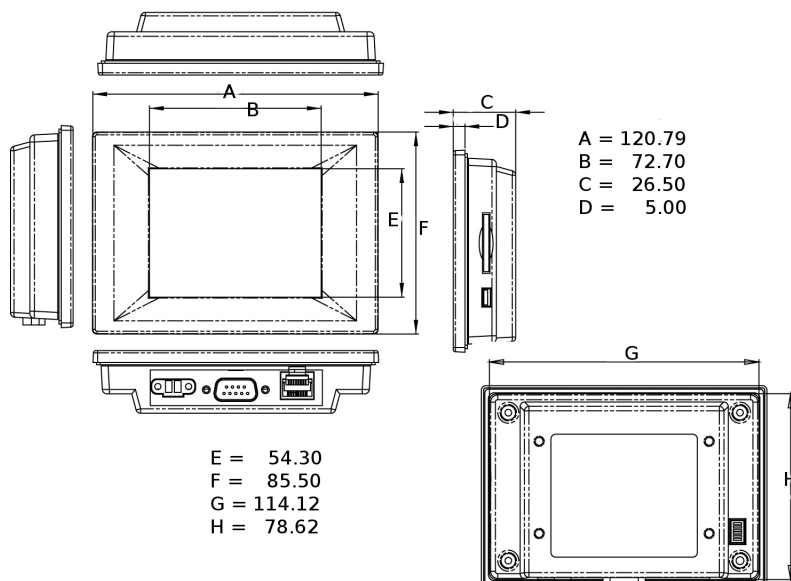

Side View

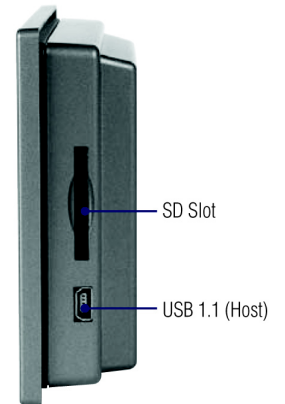

Rear View

