

SoftPLC Web Studio HMI - Models SSH-6CLT, -6CLP

FUNCTIONALITY		
Model	SSH-6CLT	SSH-CLP
Tags / Drivers	150 / 1	300 / 1
Operating System	Windows CE	Windows CE
Storage	64MB Flash on board	64MB Flash on board

SPECIFICATIONS				
SYSTEM HARDWARE		LCD DISPLAY		
CPU	312MHz Intel XScale PXA270	Display Size / Type	5.7" QVGA TFT LCD	
Ports	LAN	(1) 10/100Base-T	Max Resolution	320 x 234
	Serial	(2) full RS-232 (1) 4-pin RS-232/485	Max Colors	64K
	USB	(1) USB 1.1 host	Luminance cd/m ²	300
	Other	n/a	Viewing Angle (H/V)	140/120
Expansion	(1) Compact Flash	Backlight Life	30,000 hours	
Memory	64MB SDRAM	Contrast Ratio	500:1	
Watchdog Timer	Programmable-250ms/500ms/1sec	ENVIRONMENT		
TOUCHSCREEN		Humidity	10 ~ 95% @ 40°C, non-condensing	
Lifespan (min)	1M activations	Protection	Ingress	Front Panel: NEMA4, IP65
Light Transmission	Above 75%		Vibration	1 Grms (Operating, Random)
Resolution / Type	Linearity / 4-wire, analog resistive	Temperature	Operating	0 ~ 50°C, 32 ~ 122°F
			Storage	-20 ~ 60°C, -4 ~ 140°F
		Certifications	BSMI, CCC, CE, FCC, UL	
MECHANICAL				
Enclosure	ABS	Power	Consumption	12W
Weight (Net)	0.8 kg, 1.76 lbs		Input	18 ~ 32VDC
Cooling System	Fanless Design	Recommended Power Supply	ICO-PS4024	
Dimensions (WxHxD)	7.68 x 5.83 x 1.75 in 195 x 148 x 44.4 mm	Panel Cut-Out Dimensions	188.4 x 141.4 mm	

Dimensions

Units = mm

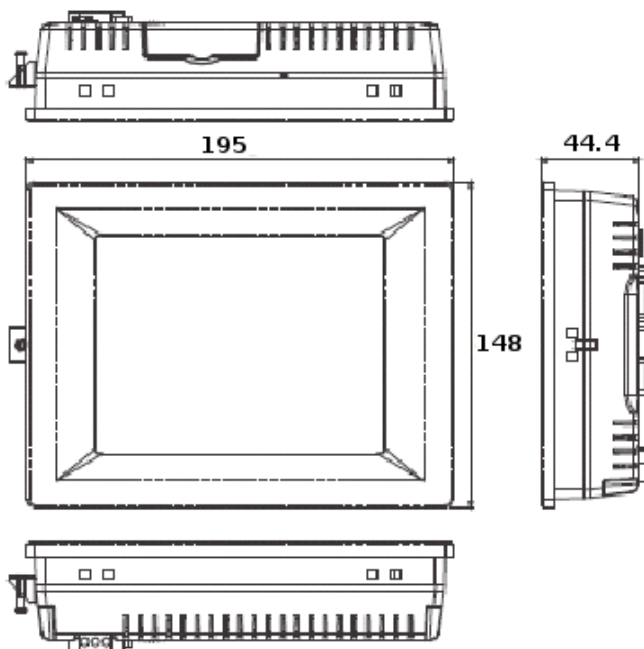

Rear View

- a. Compact Flash
- b. COM2 (RS-232)
- c. COM1 (RS-232)
- d. Fuse (3.14A)
- e. Power Receptor
- f. Power Switch
- g. COM3 (RS-485)
- h. LAN (10/100)
- i. USB 1.1 Host

