

SoftPLC Web Studio HMI - Models SSH-10CLT, -10CLP, -10CI5, -10XLP, -10XI5

FUNCTIONALITY					
Model	SSH-10CLT	SSH-10CLP	SSH-10CI5	SSH-10XLP	SSH-10XI5
Tags / Drivers	150 / 1	300 / 1	1500 / 3	300 / 1	1500 / 3
Operating System	Windows CE	Windows CE	Windows CE	WinXPe	WinXPe
Storage	2GB Compact Flash	2GB Compact Flash	2GB Compact Flash	8GB Compact Flash	8GB Compact Flash

SPECIFICATIONS					
SYSTEM HARDWARE			LCD DISPLAY		
CPU	1.6GHz CeleronM		Display Size / Type	10.4"	SVGA TFT LCD
Ports	LAN	(2) 10/100Base-T	Max Resolution	800 X 600	
	Serial	(2) RS-232 (1) RS-232/485/422	Max Colors	260K	
	USB	(2) USB 2.0	Luminance cd/m ²	400	
	Other	(1) PS/2	Viewing Angle (H/V)	140/110	
Expansion	(1) PCI-104, HDD/SDD Optional		Backlight Life	50,000 hours	
Memory	512MB DDR SDRAM		Contrast Ratio	500:1	
Watchdog Timer	1sec (system)		ENVIRONMENT		
TOUCHSCREEN			Humidity	10 ~ 95% @ 40°C, non-condensing	
Lifespan (min)	1M activations		Protection	Ingress	Front Panel: NEMA4, IP65
Light Transmission	Above 75%			Vibration	2 Grms (Operating, Random)
Resolution / Type	Linearity / 8-wire, analog resistive		Temperature	Operating	0 ~ 50°C, 32 ~ 122°F
				Storage	-20 ~ 60°C, -4 ~ 140°F
			Certifications	BSMI, CCC, CE, FCC, UL	
MECHANICAL					
Enclosure	Die-Cast Aluminum Alloy		Power	Consumption	60W
Weight (Net)	3.5 kg, 7.72 lbs			Input	18 ~ 32VDC
Cooling System	Fanless Design		Recommended Power Supply	ICO-PS12024	
Dimensions (WxHxD)	11.26 x 8.9 x 2.28 in	286 x 26 x 58mm	Panel Cut-Out Dimensions	279.58 x 219.5mm	

Dimensions Units = mm

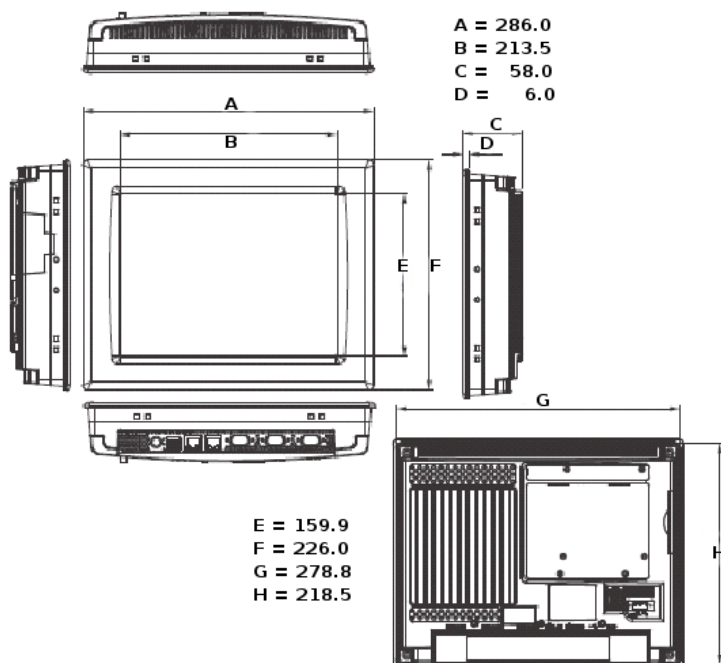

Rear View

- a. COM (RS-232)
- b. COM (RS-232/422/485)
- c. LAN (10/100/1000)
- d. USB 2.0
- e. PS/2
- f. Compact Flash
- g. Fuse (3.15A)
- h. Power Switch, Power Receptor
- i. HDD Cover
- j. PCI-104

