

SoftPLC Web Studio HMI - Models SSH-17XLP, -17XI5

FUNCTIONALITY		
Model	SSH-17XLP	SSH-17XI5
Tags / Drivers	300 / 1	1500 / 3
Operating System	WinXPe	WinXPe
Storage	8GB Compact Flash	8GB Compact Flash

SPECIFICATIONS				
SYSTEM HARDWARE		LCD DISPLAY		
CPU	1GHz CeleronM, 512k Cache	Display Size / Type	17" SXGA TFT LCD	
Ports	LAN	(2) 10/100/1000Base-T	Max Resolution	1280 X 1024
	Serial	(3) RS-232	Max Colors	16.7 M
	USB	(4) USB 2.0	Luminance cd/m ²	300
	Other	PS/2 keyboard, PS/2 mouse, VGA, MIC, Line-In, Line-Out	Viewing Angle (H/V)	160/160
Expansion	HDD/SDD, PCI-104, RS-422/485	Backlight Life	50,000 hours	
Memory	1GB DDR2 SDRAM	Contrast Ratio	800:1	
Watchdog Timer	1~255 sec (system)	ENVIRONMENT		
TOUCHSCREEN		Humidity	10 ~ 95% @ 40°C, non-condensing	
Lifespan (min)	1M activations	Protection	Ingress	Front Panel: NEMA4, IP65
Light Transmission	Above 75%		Vibration	1 Grms (Operating, Random)
Resolution / Type	Linearity / 8-wire, analog resistive	Temperature	Operating	0 ~ 45°C, 32 ~ 113°F
			Storage	-20 ~ 60°C, -4 ~ 140°F
		Certifications	BSMI, CCC, CE, FCC, UL	
MECHANICAL				
Enclosure	Die-Cast Al (front bezel), ABS +PC (housing)	Power	Consumption	100W
Weight (Net)	8 kg, 17.64 lbs		Input	18 ~ 32VDC
Cooling System	Fanless Design	Recommended Power Supply	IOC-PS12024	
Dimensions (WxHxD)	16.3 x 13.68 x 3.66 in 414 x 347.5 x 93mm	Panel Cut-Out Dimensions	400.8 x 334.3 mm	

Dimensions Units = mm

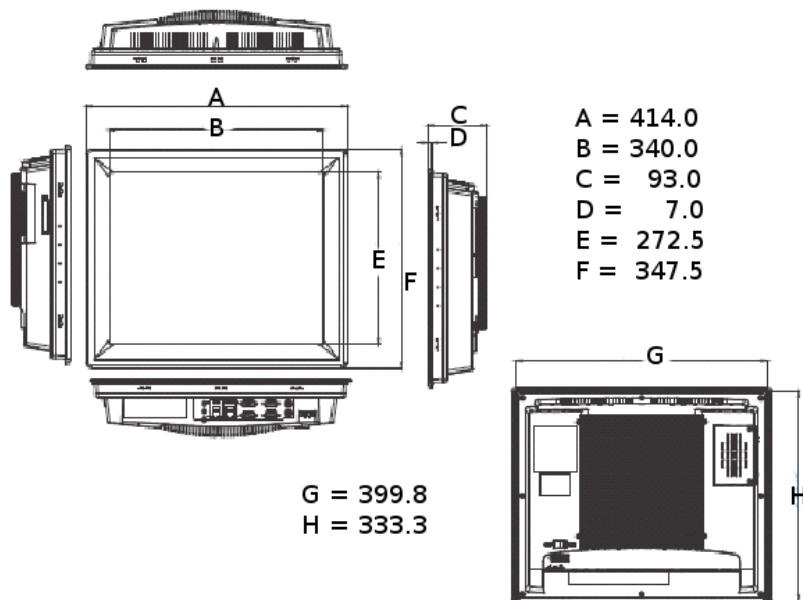

Rear View

- a. Power Switch (Fuse)
- b. Power Receptor
- c. PS/2
- d. COM (RS-232)
- e. VGA
- f. USB 2.0
- g. Audio (MIC, Line in, Line out)
- h. 2.5: SATA HDD Housing
- i. LAN (10/100/1000)

